

## HOW TO IDENTIFY PUMPS

For each pump type, the oil inlet pipe has a unique position that corresponds to a specific number of degrees

### How to view the pump

You first need to identify two principal points on the pump:

- Pump rear (defined as the side opposite the pulley)
- Oil inlet pipe

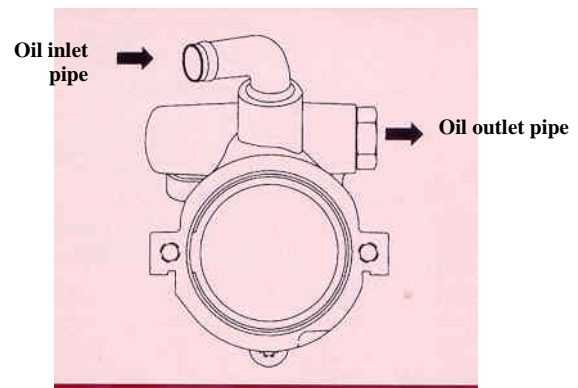
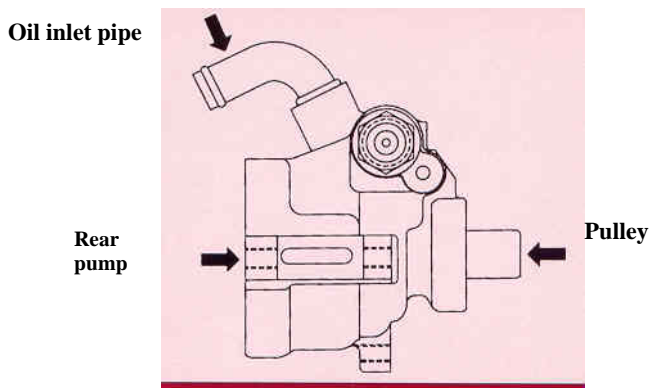

### How to identify the pumps

Stand facing the pump rear and observe the position of the oil inlet pipe. If both pieces are facing you, then the angle is said to be 0° (see figure 1).

To determine the exact angle, go round clockwise (see figures 2, 3 and 4).

Figure 1

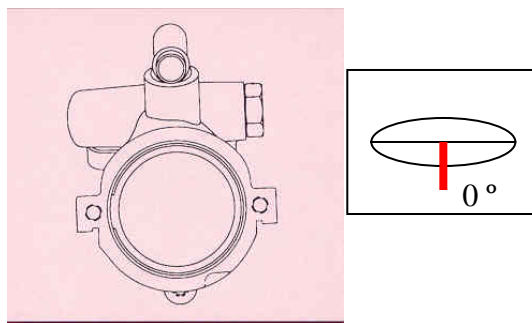

Figure 2

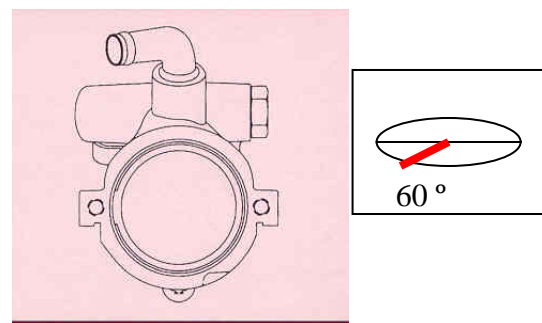

Figure 3

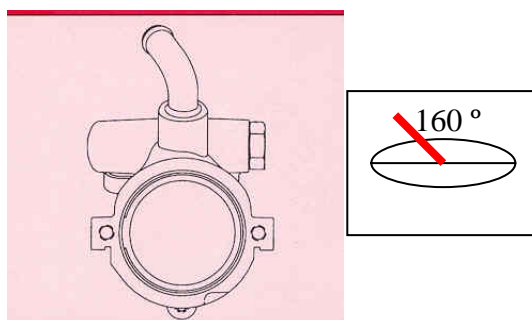

Figure 4

